

BlazeCut Automatic Fire Suppression

System Manual

Specification, Installation and Operation

T Series Systems with FK-5-1-12

TxxxFK(S)(B)(-E)



TABLE OF CONTENTS

1	INTRODUCTION	4
2	BASIC INFORMATION ABOUT THE SYSTEM	5
2.1	EXPLANATION OF MODEL PART NUMBERS	5
2.2	RETAIL PACKAGE CONTENTS	6
2.3	TECHNICAL SPECIFICATION AND TYPES	7
3	SYSTEM DESIGN LIMITATIONS	9
3.1	GENERAL RULES FOR DESIGN	9
3.2	TOTAL FLOODING APPLICATIONS	10
3.3	MAXIMUM VOLTAGE APPLICATION	11
3.4	ISO 9094 REQUIREMENTS	12
3.5	APPLICATIONS INVOLVING LITHIUM BATTERIES	13
3.6	HAZARD VOLUME DETERMINATION	13
4	COMPONENTS OF THE SYSTEM AND THEIR DESCRIPTION	15
5	INSTALLATION INSTRUCTIONS	17
5.1	FOLLOW THE FOLLOWING INSTRUCTIONS DURING INSTALLATION	17
5.2	GENERAL WARNING LABEL	20
6	INSTRUCTIONS FOR FUNCTIONALITY, INSPECTION AND MAINTENANCE	21
6.1	VISUAL INSPECTION	21
6.2	PRESSURE INSPECTION OF THE SYSTEM	21
7	FIRE PROCEDURE FOR SYSTEM ACTIVATION	21
8	INFORMATION ON EXTINGUISHING AGENT USED	22
8.1	DESCRIPTION OF THE EXTINGUISHING AGENT	22
8.2	PERMISSIBLE USES	23
8.3	LIMITED USES	24
8.4	SOME PHYSICAL AND CHEMICAL PROPERTIES	24
9	FIRST AID INSTRUCTIONS	25
10	CERTIFICATION AND TESTING	25
11	T SERIES CLAIMS AND WARRANTY	25
12	LIST OF ANNEXES	26
ANNEX 1: PRESSURE MONITORING	27
A1.1.	SIGNALLING UNITS	27
A1.2.	ALARM PANEL	28
ANNEX 2: PRESSURE MONITORING AND ELECTRICAL COMPONENTS	29
A2.1.	PRESSURE SWITCH MODELS TXXXFKS	29
A2.2.	ECONOMICAL PRESSURE SWITCH MODELS TXXXFKS-E	31
A2.3.	CONNECTION TO AN EXTERNAL RELAY	32

AUTOMATIC FIRE SUPPRESSION SYSTEMS



A2.4. ELECTRICAL CABLES AND CONDUITS..... 32

ADDITIONAL NOTES 34

1 INTRODUCTION

1.1.1 MANUFACTURER INFORMATION

BlazeCut s.r.o., Triblavinská 3191, 90025 Chorvátsky Grob, Slovakia

GLOBAL HEAD OFFICE

BlazeCut Pty Ltd., Level 24, Three International Towers, 300 Barangaroo Avenue, Sydney, NSW 2000, Australia

+61 2 8006 1300

www.BlazeCut.com; customerservice@blazecutgroup.com

1.1.2 INSTRUCTIONS FOR USE OF THE MANUAL

This manual is intended to supply technical information for trained and authorized personnel by BlazeCut Group. Any personnel performing installation, inspection, maintenance or replacement of components with the BlazeCut system shall have this manual available and proceed solely in accordance with it. Failure to follow the instructions in this manual and any other BlazeCut manuals may result in loss of warranty, a system malfunction, causing damage to the protected equipment and may present serious danger to the life and health of others.

1.1.3 SAFETY FIRST

Please read this manual in its entirety. Operation and installation instructions need to be fully understood before this BlazeCut product is installed. Failure to do so may void warranty. Your local governing regulations for safety and compliance must be followed.

1.1.4 WARNINGS AND CAUTIONS



This symbol within the manual represents warning of specific risks, dangers, or warning of described procedures. Failure to follow the instructions in the text marked with this symbol may result in loss of warranty, damage to property, threat to safety or life of persons performing the operation on the system or persons in the vicinity. Do not proceed without following the instructions marked with such symbols.

1.1.5 FURTHER INFORMATION

BlazeCut® is a registered trademark of BlazeCut and is recorded in the Register of Community Trade Marks.

If any of the instructions in this manual are unclear or in case of further questions contact the BlazeCut Team.

This document is the property of BlazeCut. It is prohibited to reproduce it, copy it in whole or in part, or provide third parties with any related information without prior written consent of BlazeCut.



WARNING

Please ensure that the safety instructions are fully understood before the equipment is put into service.

Do not modify any part of the BlazeCut components as this may cause serious injury or a failure of the system.

Always wear the appropriate protective equipment and clothing whilst installing or servicing.

2 BASIC INFORMATION ABOUT THE SYSTEM

2.1 EXPLANATION OF MODEL PART NUMBERS

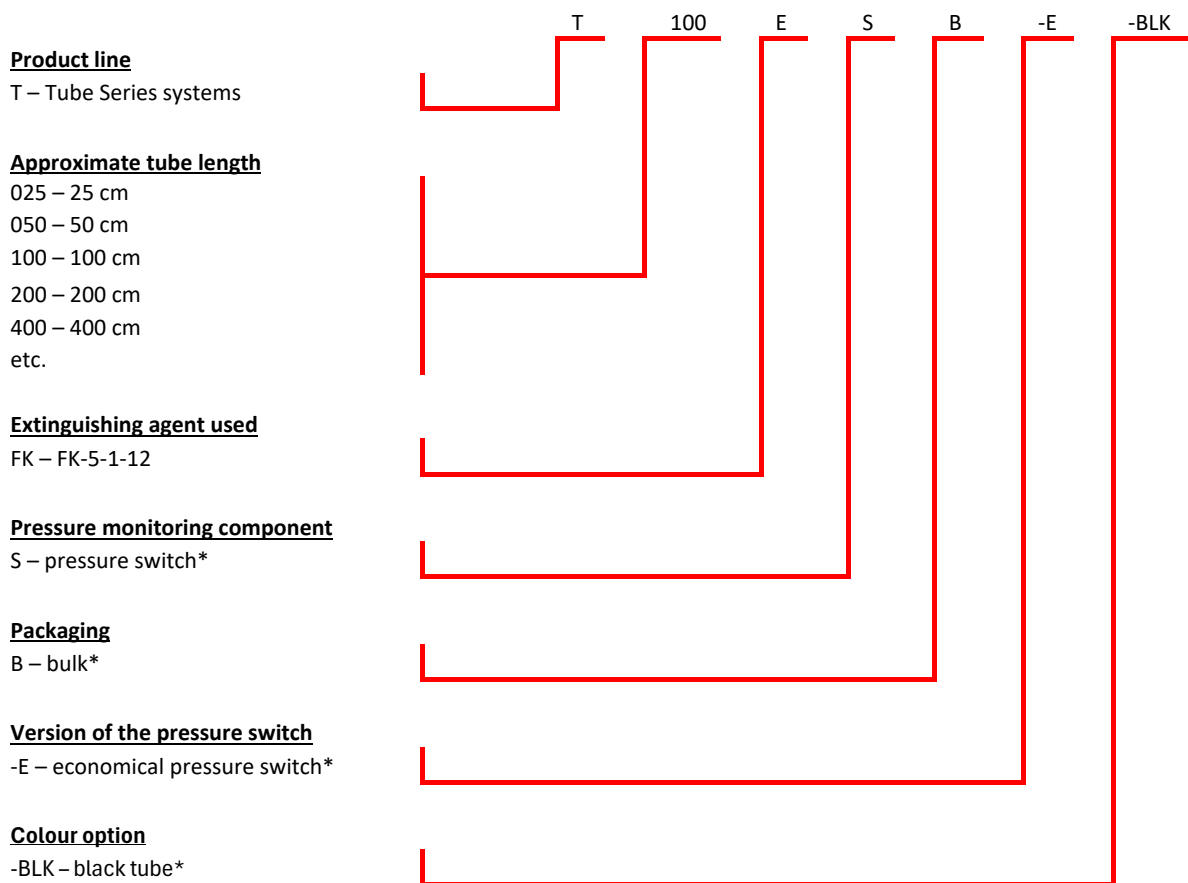

NOTE

**Only present on relevant versions.*

For full details on pressure switch options please go to [ANNEX 1: PRESSURE MONITORING](#)

Example: T200FKS – includes BlazeCut tube (T) system with length 200 cm (200) with the extinguishing agent used FK (FK-5-1-12), with a standard pressure switch (S)

Example 2: T400FKSB-E – includes BlazeCut tube (T) system with length 400 cm (400) with the extinguishing agent used FK (FK-5-1-12), with an economical pressure switch (Sx-E), bulk with no box packaging (B)

2.1.1 DESCRIPTION OF THE SYSTEM

Commercial name: BlazeCut T Series

Characteristics: Automatic Fire Suppression System

Type: Tube Series (T Series)

Functionality: The BlazeCut T Series with FK-5-1-12 system is designed to protect small enclosed or semi enclosed spaces with greater risks of fire. The BlazeCut T Series with FK-5-1-12 system operates automatically without any external power source. Extinguishing agent is stored in the tube, which also serves to apply extinguishing agent directly to the fire at its source. In the case of fire, the detection tube degrades by the effect of fire or high temperature and melts. Extinguishing agent is then released through a nozzle that is created.

AUTOMATIC FIRE SUPPRESSION SYSTEMS



BlazeCut T Series with FK-5-1-12 is suitable for protection of spaces such as:

- Electrical switchboards, fuse boxes, electrical supply sources, battery compartments, car batteries, inductors, MCC Cabinets.
- Other enclosed applications (network installations, servers, audio-video equipment, automatic teller machines, electric fuel bowsers, 3D printers etc).

IMPORTANT!

BlazeCut T Series TxxxKF(S)(B)(-E) with FK-5-1-12 are not suitable for combustion engine compartments and other environments with temperatures exceeding operating temperatures.

2.2 RETAIL PACKAGE CONTENTS

Table 1: Standard Retail package contents

Component	Amount
BlazeCut T Series Fire Suppression System	1
Clean extinguishing agent FK-5-1-12	0.05 kg – 1.06 kg
High Temperature cable ties for installation (part ACT528)	3 – 18
General warning label ALA008	1
User manual	1
Information about the substance	1
BlazeCut sticker	1



The BlazeCut system was designed and tested as a whole using original components with specific properties. Using components and spare parts other than those supplied by the manufacturer is prohibited and may change the functionality of the system and causes loss of warranty. Fastening components for the tube are exempted, provided other installation and maintenance instructions are followed and provided they are suitable for use in the protected equipment (heat resistance etc.). To order original spare parts and for further information contact the supplier of the BlazeCut system.

NOTE

Only the 0.25 to 4 metre systems can be supplied in a retail box.

2.3 TECHNICAL SPECIFICATION AND TYPES

Table 2: Types of BlazeCut T Series systems described in this manual.

Type name	Caption
T025FK(S)(B)(-E)	T – tube
T050FK(S)(B)(-E)	Three-digit number – approximate length of the tube in cm
T100FK(S)(B)(-E)	FK – extinguishing agent used FK-5-1-12
T200FK(S)(B)(-E)	S – IP65 Pressure switch fitted (outdoor and mobile applications)
T300FK(S)(B)(-E)	B – Bulk packed with no box, manuals or cable ties. Contains only T Series system and warning label
T400FK(S)(B)(-E)	-E – IP54 Economical pressure switch fitted

Material of the tube: heat sensitive plastic
 Material of the fittings: stainless steel AISI 303
 Material of the pressure gauge: nickel plated brass
 Outer diameter: 19 mm (tube), 22 mm (fittings)
 Minimum bending radius: 160 mm (6.30 in)
 Standard operation pressure at 20 °C: 7 bar

NOTE

Due to physical and chemical properties of the agent, pressure build-up in the tube will occur with increasing ambient temperature. The higher the ambient temperature, the higher the pressure will be in the tube and vice versa.

Table 3: BlazeCut T Series with FK-5-1-12 system details – Standard model

Model	Type of agent	Amount of agent	System gross weight	System length	Operating temperature in the enclosure	Activation temperature
T025FK	FK-5-1-12	0.05 kg ± 2 g (0.11 lb ± 0.07 oz)	0.21 kg (0.46 lb)	28 cm (11.02 in)	0 °C to +50 °C (32 °F to +122 °F)	149 °C ± 3 °C (300 °F ± 5 °F)
T050FK	FK-5-1-12	0.12 kg ± 2 g (0.26 lb ± 0.07 oz)	0.31 kg (0.68 lb)	53 cm (20.87 in)		
T100FK	FK-5-1-12	0.27 kg ± 2 g (0.59 lb ± 0.07 oz)	0.53kg (1.17 lb)	113 cm (44.48 in)		
T200FK	FK-5-1-12	0.53 kg ± 5 g (1.17 ± 0.17 oz)	0.90 kg (1.98 lb)	215 cm (84.64 in)		
T300FK	FK-5-1-12	0.80 kg ± 5 g (1.76 ± 0.17 oz)	1.28 kg (2.82 lb)	319 cm (125.59 in)		
T400FK	FK-5-1-12	1.06 kg ± 5 g (2.34 ± 0.17 oz)	1.67 kg (3.68 lb)	422 cm (166.14 in)		

Table 4: BlazeCut T Series FK system details – with integrated pressure switch IP65

Model	Type of agent	Amount of agent	System gross weight	System length	Operating temperature in the enclosure	Activation temperature
T025FKS	FK-5-1-12	0.05 kg ± 2 g (0.11 lb ± 0.07 oz)	0.34 kg (0.75 lb)	35 cm (13.78 in)	0 °C to +50 °C (32 °F to +122 °F)	149 °C ± 3 °C (300 °F ± 5 °F)
T050FKS	FK-5-1-12	0.12 kg ± 2 g (0.26 lb ± 0.07 oz)	0.43 kg (0.95 lb)	60 cm (23.62 in)		
T100FKS	FK-5-1-12	0.27 kg ± 2 g (0.59 lb ± 0.07 oz)	0.66 kg (1.46 lb)	120 cm (47.24 in)		
T200FKS	FK-5-1-12	0.53 kg ± 5 g (1.17 ± 0.17 oz)	1.03 kg (2.271 lb)	222 cm (87.40 in)		
T300FKS	FK-5-1-12	0.80 kg ± 5 g (1.76 ± 0.17 oz)	1.41 kg (3.11 lb)	326 cm (128.34 in)		
T400FKS	FK-5-1-12	1.06 kg ± 5 g (2.34 ± 0.17 oz)	1.81 kg (3.99 lb)	429 cm (168.89 in)		

Table 5: BlazeCut T Series system details – with integrated economical pressure switch

Model	Type of agent	Amount of agent	System gross weight	System length	Operating temperature in the enclosure	Activation temperature
T025FKS-E	FK-5-1-12	0.05 kg ± 2 g (0.11 lb ± 0.07 oz)	0.24 kg (0.53 lb)	31 cm (12.20 in)	0 °C to +50 °C (32 °F to +122 °F)	149 °C ± 3 °C (288 °F ± 5 °F)
T050FKS-E	FK-5-1-12	0.12 kg ± 2 g (0.26 lb ± 0.07 oz)	0.33 kg (0.73 lb)	56 cm (22.05 in)		
T100FKS-E	FK-5-1-12	0.27 kg ± 2 g (0.59 lb ± 0.07 oz)	0.56 kg (1.24 lb)	116 cm (45.67 in)		
T200FKS-E	FK-5-1-12	0.53 kg ± 5 g (1.17 ± 0.17 oz)	0.93 kg (2.05 lb)	218 cm (85.83 in)		
T300FKS-E	FK-5-1-12	0.80 kg ± 5 g (1.76 ± 0.17 oz)	1.31 kg (2.89 lb)	322 cm (126.77 in)		
T400FKS-E	FK-5-1-12	1.06 kg ± 5 g (2.34 ± 0.17 oz)	1.71 kg (3.77 lb)	425 cm (167.32 in)		

2.3.1 MARKING



T300FK
SN:25390456

System model: TxxxFK
SN: 8-digit number

Every T Series manufactured after 2025-10-1 has a permanent marking of the system model and unique serial number with a week and year of manufacture.

2.3.2 OPTIONAL COMPONENTS

The BlazeCut T Series can send a signal after its activation by using a pressure switch with an electronic output. The external alarm or signalling device connects to the pressure switch and a signal is sent at the time of activation, alerting the driver or personnel with light and sound signals. These components can be connected to any type of T Series equipped with a pressure switch. BlazeCut recommends where the T Series is installed into applications above 480 V, a risk assessment must be completed and that the application is immediately de-energized via the use of a T Series pressure switch model. All pressure switches must be fitted to the T Series in the factory before supply.

Installation, use, function and service of selected optional components is described in annexes of the Installation and service manual or supplied as a separate manual. For more information contact the supplier.



TxxxFKS models



TxxxFKS-E models

3 SYSTEM DESIGN LIMITATIONS

3.1 GENERAL RULES FOR DESIGN

3.1.1 WARNINGS



The BlazeCut fire system is a suppression system only and is not designed or intended to extinguish all fires. Where there are high airflows and a high accumulation of combustible materials, this will dramatically alter the systems performance. Always consider supplementary firefighting equipment be available in case system does not totally extinguish a fire. For more information about the use of the system in an area occupied by persons, please contact your supplier.



Where there are high risks of power arcing, BlazeCut recommends T Series to be installed with a pressure switch on all applications of 240 V and above, so that the application is immediately de-energized via the use of a T Series pressure switch model.



Install and use the BlazeCut T Series with FK-5-1-12 with originally supplied components. Do not replace anything in the system. The use of external components not approved by the manufacturer, for example beacons and alarms, will not be the responsibility of BlazeCut and no warranty or claim will be acknowledged in this regard.



The BlazeCut T Series with FK-5-1-12 is designed as an independently operating unit. It is not possible to connect several independent systems to one larger system.



The system may be installed only by adult persons, who are physically and mentally capable. Incorrect interference with the system may cause malfunction of the system and may threaten the safety and health of people.



The system is not designed to be used as portable fire extinguisher. Do not try to suppress fire by holding the system in hands or sprinkling the extinguishing agent directly into the fire. Do not use the system in any other way than described in this manual.

BlazeCut T Series systems do not cover fully open applications and are only suited to fully enclosed or semi enclosed applications.

The fire suppressing depends on many other factors apart from the amount of extinguishing agent, such as the properties of the flammable substances in the space, shape and degree of closure of the space, air circulation and ambient temperature. In order to reach desired extinguishing concentration and effective use of BlazeCut system consult the choice of type, amount of agent and installation method with the supplier of the system.

It is necessary that conditions in the protected area are in accordance with allowed parameters of the system, especially minimum and maximum temperature in the protected area.

Remember that there are a lot of factors and variables that affect the extinguishing process in case of fire. It is not possible to guarantee total suppression of fire in the protected equipment under all circumstances.

Use of the system is also limited by the properties of the extinguishing agent and its possible application. Detailed information is included in Chapter [8](#).

3.1.2 PRESSURE TUBE

The plastic tube serves as storage for the extinguishing agent. It is filled with extinguishing agent FK-5-1-12 and the amount depends on the type of system. The Extinguishing agent is in the form of liquefied gas. Due to physical and chemical properties of the agent, pressure in the tube can vary depending on the ambient temperature.



The T Series system is under constant pressure. Do not damage, puncture or throw the system. During transportation, secure the system against movement. During transfer do not rub the system against the ground or objects. Do not try to repair a damaged tube. Do not store or transport the system in the vicinity of strong sources of heat, aggressive chemical substances (caustic, corrosive substances). Prevent contact with sharp objects, vibrations or loading with other objects. Store in a dry and well-ventilated room.

Table 6: Values of pressure in the tube at given temperatures

Temperature [°C]	0	10	20	30	40	50	60	70	80	90
Pressure [bar]	6.4	6.7	7	7.3	7.7	8.2	8.7	9.3	10	10.8

3.1.3 BLAZECUT DESIGN CALCULATION

BlazeCut design the volumetric calculation on a theoretical sealed equipment volume and calculate the gas requirement meeting and exceeding the minimum design concentration according to NFPA 2001:2025 requirements. (Please refer to the BlazeCut gas concentration table for T Series). For applications higher than 480 V consideration to increased gas concentrations are required as part of the risk assessment process.

Maximum volume coverage depends on two major factors: Minimum ambient temperature in the protected equipment and design concentration required. To guide which system to select below tables list the maximum volume coverage for two major fire risk areas: Electrical Fires. The design concentrations in tables are to cover most of standard applications like fixed applications with Class A and electrical fires.

NOTE

For applications with different design concentration required, use the BlazeCut Calculator tool and Concentration Table or contact the supplier of the system.

3.2 TOTAL FLOODING APPLICATIONS



BlazeCut system is designed to protect equipment in closed spaces. Use in partially or completely open spaces or spaces with strong air circulation may significantly decrease the efficiency of the system.

Total flooding clean agent fire extinguishing systems shall be used to protect hazards that are in enclosures. A total flooding application is defined by a closed area with maximum unclosable openings not exceeding 0.2 % of the total area of all four sides, top, and bottom of the enclosure.

To guide which system to select below tables list the maximum volume coverage for each agent weight in certain design concentration. The design concentrations in tables are to cover most of standard applications for respective agent. The design concentration is to cover most of fixed applications with Class A and electrical fires.

Table 7: Design concentrations for FK-5-1-12

Class A Fires		4.5*	
Energized Electrical Fires <480 V		4.5*	
Energized Electrical Fires ≥480 V		10.0*	
Class B and C Fires			
1-Butane	6.4	Isopropanol Alcohol	6.4
1-Propanol	7.0	Methane	7.3
2-butoxyethanol	6.8	Methanol	8.5
Acetone	5.6	Methyl Ethyl Ketone	5.9
Acetonitrile	4.2	Methyl Isobutyl Ketone	5.7
Commercial Heptane	5.7	Methyl Tert Butyl Ether	6.0
Commercial Hexanes	5.6	n-Heptane	5.9
Cyclohexane	5.9	n-Pentane	6.1
Cyclopentanone	6.0	Propane	7.5
Denatured Alcohol	6.9	Pyrrolidine	6.1
Diesel fuel	4.4	Tetrahydrofuran	6.5
Diethyl Ether	6.4	Toluene	4.6
Ethanol	7.2	Transformer Oil	5.9
Ethyl Acetate	6.1	2,2,4-trimethylpentane	6.1
Gasoline-87 Octane Unleaded	5.9	Isooctane	6.1
Hexene	6.0		

NOTE

Minimum design concentration according to NFPA 2001 (2025) and FM 4-9 (revision April 2025).

Table 8: Design concentrations of FK-5-1-12 according to BS EN 15004-2:2020

Fire Class	Concentration
Class A Standard	5.3 %
Class A Higher	5.6 %
Class B	5.9 %

Table 9: Volume coverage with 4.5 % design concentration for Electrical fires

Temperature [°C]	Maximum volume coverage in m ³ with 4.5 % design concentration					
	T025FK	T050FK	T100FK	T200FK	T300FK	T400FK
0	0.08	0.17	0.38	0.75	1.12	1.49
5	0.08	0.17	0.39	0.76	1.14	1.52
10	0.08	0.17	0.40	0.78	1.17	1.55
15	0.08	0.18	0.40	0.79	1.19	1.58
20	0.08	0.18	0.41	0.81	1.21	1.61
25	0.08	0.18	0.42	0.82	1.24	1.64
30	0.08	0.19	0.43	0.84	1.26	1.67
35	0.09	0.19	0.44	0.85	1.28	1.71
40	0.09	0.19	0.44	0.87	1.31	1.74
45	0.09	0.20	0.45	0.89	1.33	1.77
50	0.09	0.20	0.46	0.90	1.35	1.80

3.3 MAXIMUM VOLTAGE APPLICATION



BlazeCut recommends where the T Series is installed into applications above 480 V, a risk assessment must be completed and that the application is immediately de-energized via the use of a T Series pressure switch model.

Metal components (e.g., pressure gauge, fittings) shall be kept clear from the protected electrical equipment. Any BlazeCut system electrical components (e.g., pressure switch) in close vicinity to high voltage equipment shall be grounded. This must be carried out by a qualified electrical contractor.

AUTOMATIC FIRE SUPPRESSION SYSTEMS



Referencing below the NFPA 2001:2025 Standards Article 7.2.2.4.2.

The minimum design concentration for spaces containing energized electrical hazards supplied at greater than 480 volts that remain powered during and after discharge shall be determined by a hazard analysis and testing, as necessary.

For applications above 480 V, as each application is unique and requires a hazard analysis/risk assessment, the user/installer is responsible for any testing, if required.

Please contact BlazeCut for a copy of our hazard analysis/risk assessment form.

Referencing below FM Global Data sheet 4-9 (revision April 2025) Article 2.2.2.2.B

When the electrical equipment is not de-energized upon activation of the clean agent extinguishing system or has a time-delayed power disconnect, provide the minimum design concentration for an energized electrical fire (Class C – US classification) in accordance with [Table 10](#) for the applicable equipment voltage. If the electrical equipment is not de-energized the clean agent concentration falls below the minimum design value shown in [Table 10](#), reignition is expected.



Table 10: Minimum Design Concentrations according to FM Global 4-9 (revision April 2025)

Agent	Minimum Design Concentration, %			
	Class A	Class B ¹	Class C, ≤480 V	Class C, >480 V ^{2,3}
FK-5-1-12	4.5	5.9	4.7	10
HFC-125	8.7	11.3	9.0	20
HFC-227ea	6.7	8.7	7.0	12
HFC-23	18	19.5	20.3	Not tested ³
IG-01	38.0	52.5	42.8	60.5
IG-55	37.9	39.1	42.7	Not tested ³
IG-100	37.2	43.7	41.9	56.1
IG-541	34.2	44.7	38.5	57

- Note 1. Class B values are for hydrocarbon fuels similar to n-Heptane. Class B minimum design concentrations will vary for other ignitable liquid fuels, based on the information provided in the manufacturer’s design, installation, operation, and maintenance manual.
- Note 2. These higher concentrations need to be reviewed for restrictions when used in normally occupied areas. See Section 3.2.4 and Table 5 for information regarding No Observed Adverse Effects Limit (NOAEL) and Lowest Observed Adverse Effects Limit (LOAEL).
- Note 3. FM conducted testing that indicates higher agent concentrations are needed for high-energy arcing faults. Only certain clean agents were tested. Refer to Section 3.3 for additional information on this testing. Where an agent is listed as “not tested,” additional testing is necessary if the clean agent system is intended to protect energized electrical hazards greater than 480 volts that remain energized following discharge. Do not use an agent to protect high-energy electrical hazards if this testing has not been conducted.

IMPORTANT!

Please note the recommended increased agent concentration for Application higher than 480 V is by FM Global for Class C (US classification), Electrical applications. Please refer to FM Global for further information.

3.4 ISO 9094 REQUIREMENTS

When protecting a space containing a combustion engine there shall be a device, manual or automatic, that shuts down the engine before or during the discharge or activation.

Prior to or during system discharge, the manual and/or automatic shutdown of engines, generators, forced ventilation, or other permanently installed equipment which could compromise the levels of extinguishing medium in the protected area, shall be installed.

Where equipment shutdown as described above cannot guarantee that extinguishing medium design concentration can be maintained, shut-off dampers closing the ventilation ducts shall be installed.

For automatic systems having a single external power source, a means to indicate to the craft occupants that the power supply is active shall be installed.

The displayed information shall be in the appropriate language. The information may be represented by symbols in accordance with ISO 7010, or other relevant standards.

Where a space is protected by a fixed fire extinguishing system with manual activation capability, the following information shall be displayed near the manual release device:

Background: Yellow



3.5 APPLICATIONS INVOLVING LITHIUM BATTERIES



The BlazeCut fire suppression system will assist during a fire in enclosures containing lithium batteries, however BlazeCut cannot state that our products will extinguish a lithium battery fire in thermal runaway. BlazeCut fire suppression systems may extend a window of safety for people to evacuate and may be able to reduce overall damage to the equipment caused by the failure.

According to ISO 14520-1, 7.5.2

The minimum design concentrations used to inert atmospheres involving inflammable liquids and gases shall be determined by adding a safety factor of 10 %.

FK-5-1-12 Inerting and design concentrations

Methane: Inerting 8.8%, Minimum design: 9.7%

Propane: Inerting 8.1%, Minimum design: 8.9%

According to NFPA 2001

The minimum design concentration used to inert the atmosphere of an enclosure where the hazard is a flammable liquid or gas shall be the inerting concentration times a safety factor of 1.1.

Methane: FK-5-1-12 Inerting: 8.8%

Propane: FK-5-1-12 Inerting: 8.1% x 1.1 = 8.9 %

BlazeCut Design Concentrations

For lithium-ion battery applications, BlazeCut use the below concentrations

FK-5-1-12 Minimum design concentration: 10 %

Mandatory features

When protecting a space containing lithium batteries, instant shutdown of power supply to the batteries instigated by a BlazeCut Alarm Panel or pressure switch with a relay is required.

3.6 HAZARD VOLUME DETERMINATION

The volume calculated is a nett volume.

$$V = W \times L \times H \text{ [m}^3\text{]} \quad (1)$$

V – total volume of the enclosed space [m³]

W – width [m]

L – length [m]

H – height [m]

Calculation example for an enclosure:

Given values for an enclosure:

$$W = 1.16 \text{ m} \quad L = 5.02 \text{ m} \quad H = 1.38 \text{ m}$$

Given values for a permanent solid object:

$$W_{po} = 0.80 \text{ m} \quad L_{po} = 4.50 \text{ m} \quad H_{po} = 1.00 \text{ m}$$

$$V = W \times L \times H = 1.16 \times 5.02 \times 1.38 = 8.04 \text{ m}^3$$

3.6.1 CALCULATION OF REQUIRED AGENT

Determine the required agent quantity for hazard protection with the desired concentration. The agent amount is dependent on two major factors: lowest ambient temperature in the protected enclosure and design concentration required for the type of hazard.

$$S = k_1 + k_2 \times t \quad (2)$$

S – specific volume of the superheated agent vapor at 1 atmosphere and the temperature t [m^3/kg]

t – minimum anticipated temperature of the protected volume [$^{\circ}\text{C}$]

for HFC-227ea:

$$k_1 = 0.1269 \quad k_2 = 0.0005$$

for FK-5-1-12:

$$k_1 = 0.0664 \quad k_2 = 0.0002741$$

$$Q = \frac{V}{S} \times \frac{C}{100 - C} \quad (3)$$

Q – agent quantity [kg]

C – agent volumetric concentration at the given ambient temperature t [%]

4 COMPONENTS OF THE SYSTEM AND THEIR DESCRIPTION

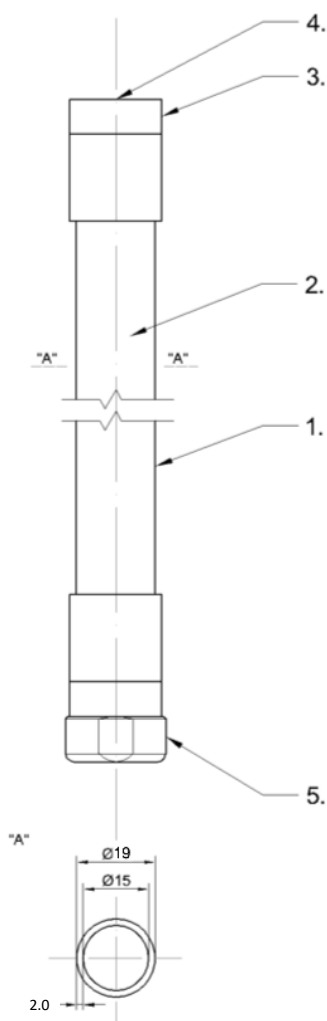

Scheme of the system and description of components, all data in millimetres

1. Pressure tube
2. Extinguishing agent FK-5-1-12
3. Fitting of the tube with outlet M10x1 and with the filling valve
4. Sealing screw (inside the fitting)
5. Pressure gauge

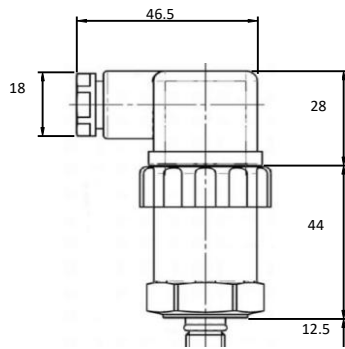

Pressure Switch (sideview)

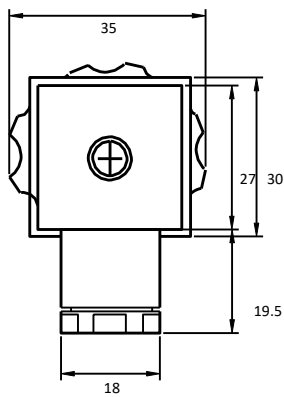

Pressure Switch (front view)

Economical Pressure Switch

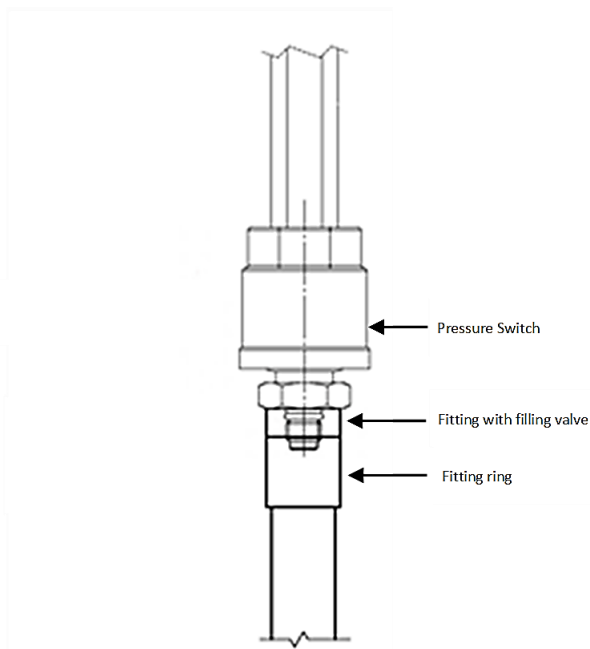
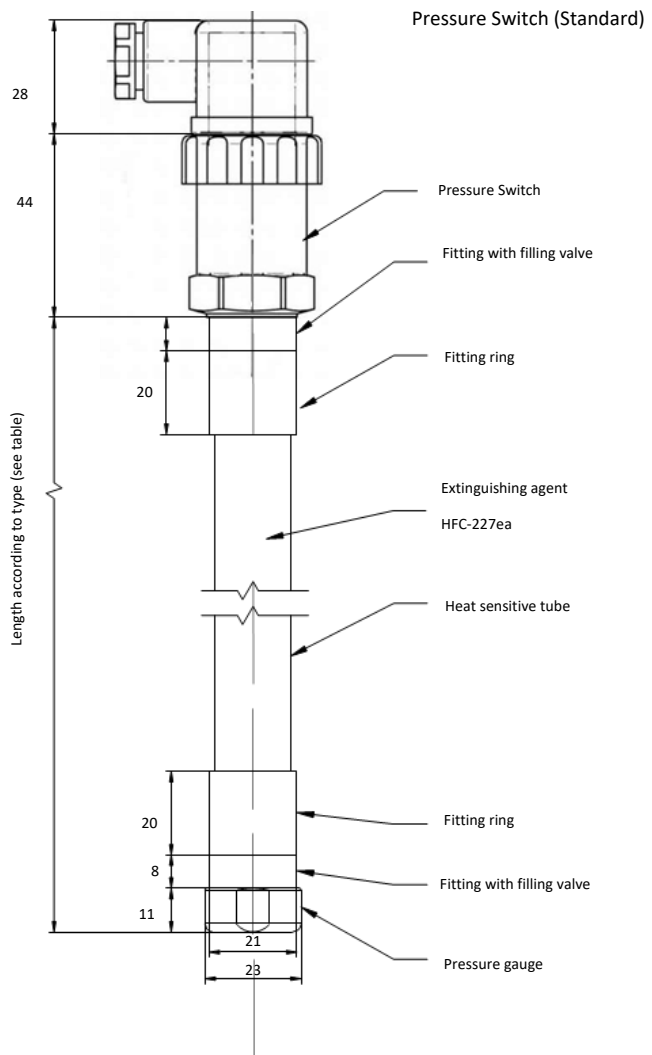
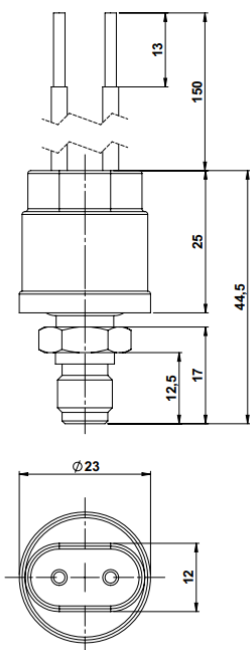



Always handle the tube as if it was under pressure, unless it is directly verified that it is completely empty.

4.1.1 FITTINGS OF THE TUBE

The Fittings of the T Series system close the tube and keep the system under pressure. The filling valves are fitted in the fittings and closed by a pressure gauge on one end and sealing screw or pressure switch on the other end. The pressure switch is fitted at the factory when ordered.



Do not try to remove fittings of the tube. Protect the fittings from corrosive substances during storage, transportation and when in use.

4.1.2 PRESSURE GAUGE

Actual pressure in the system can be determined by reading the value on the pressure gauge, which is mounted on the fitting tube. Try to install the pressure gauge so that the pressure values can be read.

NOTE

Due to physical and chemical properties of the agent, pressure in the tube can vary depending on the ambient temperature. The higher the ambient temperature, the higher pressure in the tube and vice versa (see [Table 6](#)).

5 INSTALLATION INSTRUCTIONS

5.1 FOLLOW THE FOLLOWING INSTRUCTIONS DURING INSTALLATION

1. The tube in the retail packaging is secured with cable ties. Cut the cable ties (orange) carefully, avoiding damage to the tube. Dispose of the plastic cushion and silicone protectors (red) used for packing and transport purposes.



Highlighted packing materials to be removed from T Series

2. The package contains high temperature cable ties for installation in the protected equipment. It is possible to use PVC dipped or rubber insulated metal clamps in harsher environments to prevent detachment of the tube. Do not use a steel fastening material for installation, it must be insulated. If in direct contact, steel clamps, steel cable ties or wire will cause heat concentrations on the pressure tube. This can result in a false or lower temperature actuation.
3. Place the BlazeCut T Series with FK-5-1-12 in the proximity of the protected equipment where the risk of fire is greatest (in the area of systems containing flammable liquids or gases, protected objects, electrical installations, connections, circuit breakers, inductors, batteries etc.).

4. Bend the tube to shape for the installation. A minimum bend radius of 160 mm (6.30 inches) must be maintained.
5. The tube (filled with FK-5-1-12 agent) is allowed to be mounted only in horizontal position.



Correct installation position



Forbidden positions of installation

6. The BlazeCut T Series with FK-5-1-12 must be mounted away from hot parts and cannot directly contact parts or be in proximity of parts that during operation have temperatures exceeding operating temperature of the T Series used (e.g., hot parts of inductors etc.).
7. If there are doubts on the operating temperature exceeding maximum temperature allowed for the T Series used, measure the max ambient heat in the area where the tube is to be installed. The tube may not be in direct proximity, but the radiant heat rising to the top of the equipment may exceed the maximum temperature limit, causing a false actuation.
8. For maximum efficiency, do not place the BlazeCut T Series with FK-5-1-12 behind barriers that could restrict or prevent direct penetration of extinguishing agent into the protected equipment. Do not place the T Series close to vents or openings as this may reduce the amount of agent applied to the protected equipment.
9. Proceed carefully with the installation, so no damage is caused to the tube by sharp objects. Do not break or crimp the tube. Make sure that the tube will not be damaged after closing doors or covers of





the equipment (e.g., installation of covers or enclosure etc.). No part of the system should be hit by moving parts (fans etc.).

- The BlazeCut T Series with FK-5-1-12 must be firmly mounted in the protected equipment so that it does not move. Use included cable ties or PVC dipped/rubber insulated metal P-clamps. It is acceptable to use cable ties in conjunction with P-clamps. Recommended minimum number of P-clamps is given in [Table 11](#).

Table 11: Recommended minimum number of P-clamps

T Series model	Number of P-clamps	Approximate distance
T025	2	25 cm
T050	2	50 cm
T100	3	50 cm
T200	5	50 cm
T300	7	50 cm
T400	9	50 cm







Table 12: Fastening material for T Series

Picture	Part №	Description	Material
	ACT314	Cable tie, increased heat resistance up to +125°C, 3.6 x 140 mm, black, for silicone cable and wiring	plastic
	ACT528	Cable tie, increased heat resistance up to +125°C, 5 x 280 mm, black for T Series	plastic
	APC018	P-clamp, 18 mm, 6 mm mounting hole for T Series tube	galvanized steel, rubber insert
	APC020	P-clamp, 20 mm, 9 mm mounting hole for T Series tube and end fittings	stainless steel, PVC cover

- Fasten the system to fixed interior parts of the protected equipment. Do not fasten to parts, which move during operation of the equipment. Make sure that the cable ties or clamps are not damaged during operation of the equipment. If the BlazeCut T Series with FK-5-1-12 moves out of place after installation, the extinguishing effect of the system may be decreased and part or the entire protected equipment may be damaged.
- Install the system so that it is not exposed to aggressive chemical substances (caustic, acids, solvents, corrosive substances etc.) and avoid direct influence of weather conditions and direct sunlight.
- When fastening the system make sure not to damage other parts of the equipment.
- After installation, place the general warning label (ALA008) on a highly visible area of the protected equipment. The label should be placed on an even smooth surface. Clean the surface thoroughly before sticking. Do not place the label in areas reaching high temperatures.
- Ensure to follow all local laws, for example if required, ensure a date tag is installed and dated.

AUTOMATIC FIRE SUPPRESSION SYSTEMS



-  Always wear appropriate personal protective equipment whilst installing or servicing. Use impervious working gloves and protective eyewear in case of false actuation.
-  Always isolate any equipment. Be aware of the danger posed by the protected device. Do not install and perform maintenance of the system if devices are in operation or power has not been shut down.
-  In the case of work in the vicinity of electrical equipment observe corresponding safety rules and instructions. Work on electrical installations may be performed only by qualified persons.
-  The tube has a minimum bending radius of 16 cm (6.30 inches). Do not bend the tube under this radius. Excessive bending can damage the tube where it can rupture or break. As a result of the damage the extinguishing agent can splash out and provide threat to health of persons.
-  The tube needs to be mounted away from hot parts that can exceed the burst temperature ratings. Try to avoid mounting directly above heated parts, rather mount the tube to one side of the heated parts.
-  Do not place the T Series close to vents or openings. This may reduce the amount of agent applied and retained in the protected equipment. Concentration levels may not be achieved.

5.2 GENERAL WARNING LABEL

Various high-quality UV stabilized labels are supplied with the BlazeCut system to ensure that the operator or people that may come in contact with the system are informed about its presence and operation. All labels can be reordered separately when replacement is required due to damage.

Table 13: Notification labels

Part No.	Description	Comment
ALA008	General Warning label for T Series	To notify there is a fire suppression system.
ALA019	"Fire Alarm"	label for the buzzer AWB012, AWB024, Ø 53 mm
ABS110	"BlazeCut"	promotional sticker, 110 x 68 mm
ABS220	"BlazeCut"	promotional sticker, 220 x 135 mm
ABS300	"BlazeCut"	promotional sticker AFSS, 300 x 110 mm



ALA008



ALA019



ABS110 and ABS220



ABS300



6 INSTRUCTIONS FOR FUNCTIONALITY, INSPECTION AND MAINTENANCE

The BlazeCut T Series with FK-5-1-12 does not require any special maintenance. It is recommended to visually inspect the system and its condition. Monthly inspections for harsh environments and up to three monthly for non-harsh environments.

6.1 VISUAL INSPECTION

During the movement of the tube bubbles of gas in the extinguishing agent will be visible at its highest point. This indicates that extinguishing agent is in the tube and the BlazeCut T Series with FK-5-1-12 is functional. Visually inspect the overall state of the system. Focus on possible damage to the tube, such as grooves, signs of strain (which causes the tube to change a lighter colour), dents, other deformations, corrosion of the metal parts (fittings of the tube) and any other visible signs of damage. Inspect the fitting parts of the system for any leaks and signs of leakage of extinguishing agent from the system.

6.2 PRESSURE INSPECTION OF THE SYSTEM

Due to physical and chemical properties of the agent, pressure in the tube can vary depending on the ambient temperature. The higher the ambient temperature, the higher pressure in the tube and vice versa (see Chapter 3.1.2).

Inspection and test intervals stated in [Table 14](#) minimum intervals required by the manufacturer. If the legislation in place of installation requires shorter intervals as stated in the table or additional inspections and tests, which are not stated in the table, it is necessary that these inspections are performed in accordance with this legislation.

Table 14: Overview of inspections

No	Period / interval	Obligatory scope
1.	Every 1 to 3 months	1. Overall inspection of the system for damage or wear. 2. Check mounts for being secure, replace or tighten where necessary. 3. Check for bubbles of gas in the extinguishing agent. 4. Check pressure at normal operating temperature. 5. If applicable, ensure date tag is updated.
2.	5 to 10 years	1. Dependent on being in a passive or harsh environment, the T Series may need replacing if any of the above steps fail.

IMPORTANT!

In these cases, the BlazeCut T Series with FK-5-1-12 must be replaced:

1. The system is leaking, was used or emptied from other reasons.
2. The system was exposed to direct fire.
3. The tube shows signs of damage.
4. Metal parts of the system are corroded or show visible signs of damage.

7 FIRE PROCEDURE FOR SYSTEM ACTIVATION

In case of fire in mobile equipment, the driver or operator must immediately stop the equipment, turn off the motor and perform further measures according to the operating instructions of the equipment. For example, there may be a requirement to cut-off the supply of fuel/gas supply in order to protect the persons and property surrounding the protected area. This may be in accordance with applicable legislations.

In case of fire in an enclosure, once determined the fire was extinguished, ventilate the protected equipment properly, do not enter in the area before ventilation.

Once the fault has been identified and repaired in the equipment, remove the used system from the protected equipment and replace with a new system. The same procedure should be followed after the release of extinguishing caused from other issues (system damage etc.).

7.1.1 WARNINGS



Always wear appropriate personal protective equipment whilst installing or servicing. Use impervious working gloves and protective eyewear in case of false actuation.



In case of fire the system activates automatically without previous warning. In case of fire do not come into direct proximity of the system, there is a risk of being affected by extinguishing agent. After release of extinguishing agent do not enter the protected equipment. Always consider supplementary firefighting equipment be available in case system does not totally extinguish a fire.



The system is under constant pressure. Any interference with the system is prohibited.



Any interference or repair of the system may be performed by qualified persons ensuring correct technical practice. Do not repair or replace anything in the BlazeCut T Series. System interference or non-genuine replacements shall result in loss of warranty and may cause malfunction of the system or expose danger to persons.



Do not interfere with the system if it was exposed to high temperature (as a result of operation of the protected device or after exposure to fire etc.). If the system is hot, the temperature of extinguishing agent increases and pressure in the system increases. If the pressure in the system is higher than 13 bar the system is reaching burst pressure. In this case the tube must not be mechanically stressed. Release of extinguishing agent under high pressure can cause serious injury. Wait till the system cools down.



Do not try to suppress the fire by holding the BlazeCut T Series with FK-5-1-12 close to fire or by throwing it into the fire. There can be a high danger of serious injury.

8 INFORMATION ON EXTINGUISHING AGENT USED

The BlazeCut T Series with FK-5-1-12 uses stored extinguishing agent:

Type of extinguishing agent: FK-5-1-12

Chemical name: Perfluoro (2-Methyl-3-Pentanone)

General characteristic: liquid, colourless, odourless

Amount of extinguishing agent is stated in Chapter [2.3](#) and on the information label of each system.

8.1 DESCRIPTION OF THE EXTINGUISHING AGENT

The extinguishing agent is a clean extinguishing medium and used in the BlazeCut T Series with FK-5-1-12 for volume fire suppression. Extinguishing effects are due to cooling and anticatalyst effect. Extinguishing agent siphons heat from the fire, alters the chemical chain reaction of burning, slows this reaction and stops it. Extinguishing agent is not toxic or poisonous, it does not have carcinogenic or a mutagenic effects and it is considered an environmentally accepted suppressing agent.

FK-5-1-12 is an ecological alternative and it is considered to be a next generation substitution of halon agents used in the past. Compare to chemical extinguishing substances used today (like HFC gases) FK-5-1-12 has at the moment lowest global warming potential (GWP = 1), lowest atmospheric lifetime (5 days) and zero ozone depletion potential (ODP = 0). These unique environmental features promise to FK-5-1-12 its long-term use in the future.

With volume fire suppression the efficiency of the system depends mainly on extinguishing concentration, which should be reached in the area of fire. Desired extinguishing concentration with FK-5-1-12 is lower than concentration dangerous to people.

8.1.1 MAIN ADVANTAGES OF EXTINGUISHING AGENT

- electrically non-conductive
- non-corrosive
- resistant to temperature changes
- safe for people when safety instructions are followed
- leaves no residue
- does not damage equipment or objects
- zero ODP (Ozone Depletion Potential)
- almost zero global warming potential (GWP – Global Warming Potential)

8.2 PERMISSIBLE USES

Extinguishing agent may be used for the following classes of fire:



Class A – flammable combustibles (creating flames)



Class B – flammable liquids



Class C – flammable gaseous substances



*System is suitable for fire suppression of electrical equipment under voltage**

Always consult the supplier to confirm suitability on the use of the system and the extinguishing agent in unspecified conditions.

After long exposure of extinguishing agent to heat the agent decomposes thermally creating dangerous products. In case of installation to equipment with risk of smouldering solid (e.g., wood, coal, paper, textiles etc.) use the BlazeCut T Series with FK-5-1-12 with additional components – pressure switch and output for a signalling of system activation.

Although the extinguishing agent is not toxic or poisonous, unnecessary excessive exposure of persons to its influence should be avoided. Under no circumstances should persons be exposed to the extinguishing agent for more than 5 minutes. A protected area cannot have people present when the extinguishing concentration exceeds the 10.5% LOAEL level (see toxicity data in [Table 15](#)).

The BlazeCut T Series with FK-5-1-12 system is primarily designed for small, enclosed areas and equipment where people are not normally present (or are present for a short period of time to conduct inspections, maintenance, etc.).

The system must be designed so that when the extinguishing agent is released the extinguishing concentration level, which could be dangerous to people, is not exceeded. It is also necessary to establish additional local measures to evacuate people from the protected area as soon as possible.



During the system activation the extinguishing agent is discharged from the tube under high pressure. No permanent work place should be placed less than 1 meter from the system if the system is not installed in equipment that prevents the extinguishing agent being discharged onto persons or no other barriers are in place preventing the extinguishing agent being discharged onto persons.

8.3 LIMITED USES

Extinguishing agent is not suitable for fire suppression in spaces with:

- Certain chemicals or mixtures of chemicals, such as cellulose nitrate and gunpowder, that are capable of rapid oxidation in the absence of air;
- Reactive metals such as lithium, sodium, potassium, magnesium, titanium, zirconium, uranium and plutonium;
- Metal hydrides;
- Chemicals capable of undergoing auto thermal decomposition, such as certain organic peroxidase and hydrazine.

8.4 SOME PHYSICAL AND CHEMICAL PROPERTIES

Table 15: Properties of FK-5-1-12

Property	Value
Global warming potential	1
Ozone depletion potential	0
Chemical name	Dodecafluoro-2-methylpentan-3-one
Formula	$\text{CF}_3\text{CF}_2\text{C}(\text{O})\text{CF}(\text{CF}_3)_2$ or $\text{C}_6\text{F}_{12}\text{O}$
CAS number	756-13-8
Extinguishing concentration*	4.5 % of volume
Boiling point at pressure 1 bar	49.2 °C
Freezing point	-108 °C
Critical temperature	168.7 °C
Critical pressure	1865 kPa
Critical density	639.1 kg/m ³
Density in liquid form at 25 °C	1600 kg/m ³
Pressure of saturated vapours (at 25 °C)	40.4 kPa
Molecular weight	316.04
Dielectric Strength at 1 atm, 25 °C (N ₂ =1)	2.3
Dielectric strength in kV (vapour)	16
Dielectric Strength in kV (gaseous mixture 5 % in air)	9.2
LC ₅₀ (4 h inh.)	100 000 ppm
Toxicity NOAEL	>10 % concentration, 100 000 ppm
Toxicity LOAEL	10 % concentration, 100 000 ppm
Flammability	non-flammable substance
Form	liquid
Colour	colourless substance
Odour	Slight odour

*Extinguishing concentration determined for reference substance n-Heptane

For detailed information on the extinguishing agent, ask for a safety data sheet.

8.4.1 WARNINGS



Extinguishing agent under normal (atmospheric) pressure evaporates. Do not breathe vapours. Exposure to high concentrations may cause health problems: a temporary loss of nerve activity, numbness, dizziness and confusion, loss of coordination, drowsiness, unconsciousness, irregular heartbeat, palpitations, depression, fainting, and weakness. Exposure to extreme concentrations of extinguishing agent may cause death without warning.



Extinguishing agent is heavier than air in a gaseous state. Accumulation in enclosed or low level areas may cause a lack of oxygen levels and result in suffocation. After use of the system use natural or forced ventilation and do not enter until the agent has been dispersed.



Extinguishing agent in liquid form may cause frostbite upon contact with eyes. Avoid contact of liquid extinguishing agent with eyes. For installation, inspection, maintenance and repair of the system always use eye protection - wear appropriate protective glasses with side-shields.



Extinguishing agent in liquid form may cause frostbite upon contact with skin. When a leak of liquid extinguishing agent from the system is detected, use appropriate protective impervious working gloves.



Extinguishing agent is subject to thermal decomposition and forms toxic products – hydrogen halides after exposure to high temperatures in the fire area. Avoid exposure of extinguishing agent to high temperatures. After a fire is indicated take precautions to avoid exposure of extinguishing agent to high temperatures. After the actuation of the system, secure the area by natural or forced ventilation. Use the system only in permissible ways instructed by the manufacturer.

9 FIRST AID INSTRUCTIONS

In case of direct contact with extinguishing agent proceed as follows:

9.1.1 GENERAL INFORMATION

In all cases of doubt, or when the symptoms persist, seek medical attention.

9.1.2 FOLLOWING INHALATION

Move the person to fresh air and keep them in a resting position that is comfortable for breathing. If the person is not breathing or if breathing is irregular or breathing has stopped, administer artificial respiration or oxygen by trained personnel. Loosen tight clothing such as collar, tie, waistband, and belt. Do not administer adrenaline or its derivatives. Seek medical attention immediately.

9.1.3 FOLLOWING EYE CONTACT

Carefully flush/irrigate with water for several minutes. Where applicable, remove contact lenses, if they are inserted. Continue flushing. Seek medical attention.

9.1.4 FOLLOWING SKIN CONTACT

Remove and isolate contaminated clothing and shoes. Wash immediately with plenty of soap and water

9.1.5 INGESTION

Wash out mouth with water. Consult a doctor

10 CERTIFICATION AND TESTING

The safety and performance of the BlazeCut T Series with FK-5-1-12 system was confirmed by various independent bodies.

A copy of the current certificates can be requested by emailing customerservice@blazecutgroup.com

11 T SERIES CLAIMS AND WARRANTY

11.1.1 DISTRIBUTORS

All orders should be checked within 14 days from receipt to make a valid claim of short supply or damage. Provide all information of the relevant order it relates to. Please refer to the BlazeCut warranty claim form for further details.

BlazeCut offer a 3-month window for the sale of the goods to a retail transaction. This effectively gives a 27-month warranty on T Series for distributors shelf stock.

11.1.2 END USERS AND GENERAL PUBLIC

BlazeCut offer a five-year warranty on all T Series models. You can register your warranty by visiting www.blazecut.com



12 LIST OF ANNEXES

[ANNEX 1: PRESSURE MONITORING](#)

[ANNEX 2: PRESSURE MONITORING AND ELECTRICAL COMPONENTS](#)

ANNEX 1: PRESSURE MONITORING

A1.1. SIGNALLING UNITS

Table 16: Signalling units

Part No	Description
ASU001	Signalling unit, light and sound, 81 dB, CE, 6-28 V DC, CE. Suitable for indoor, fixed, low vibration installations
ASU002	Signalling unit red, sounder and beacon with high base, 114 dB, IP44, EN54-3/CE/LPCB, 24 V DC. Suitable for indoor, fixed, low vibration installations
ASU003	Signalling unit red, sounder and beacon with high base, 101 dB(A), IP65, 18-24 V DC, CE, EN54-3. Suitable for fixed, low vibration installations
ASU004	Signalling unit, combined sounder and beacon, 97 dB, IP65 - Type B - 20-30 V DC, CE, EN54-3, -20 °C up to 70 °C. Suitable for outdoor, fixed, low vibration installations
ASR001	Sounder red, multi tone with high base, 92 dB to 112 dB, IP65, CE/VdS, LPCB, 9-15 V DC, CE, EN54-3. Suitable for fixed, low vibration installations
ASR002	Sounder, multi tone with high base, IP65, EN54-3, voltage range 9-29 V DC, operating temperature: -25 °C +80 °C, deep base. Suitable for fixed, low vibration installations
ABR001	Beacon red xenon, IP65, CE, VdS, 9 V-60Vdc, CE, EN54-3. Suitable for fixed, low vibration installations
ABR002	Beacon red LED, IP65, CE, R10, 12-24 V DC, -20°C to +50°C, 3 bolt mounting. Suitable for outdoor mobile applications.
ASB001	Sounder black, 97 dB, IP65, SAE J994 Type C, AMCA, UL, CE, E, 12-24 V DC, -40°C to +85°C. Suitable for outdoor mobile applications.
AWB012	Warning buzzer with red LED dots, 12 V DC, 80 dB (@1m), IP50, -20 to +50 °C, stainless steel, 29 mm diameter. Suitable for fixed and mobile installations. Includes ALA019 label.
AWB024	Warning buzzer with red LED dots, 24 V DC, 80 dB (@1m), IP50, -20 to +50 °C, stainless steel, 29 mm diameter. Suitable for fixed and mobile installations. Includes ALA019 label.
ASB8666	Sign Board optical acoustic with text: "EXTINGUISHING IN PROGRESS", size of text: 135x320 mm, IP65, 12/24 V, 100 dB @1 m, -10 °C to +50 °C, CE, fixed applications



ASU001



ASU002, ASU003



ASU004



ASR001



ABR001



ABR002



ASB001



AWB012 and AWB024



ASB866

A1.2. ALARM PANEL

Table 17: Alarm panel and accessories

Part No	Description
AAP310	Alarm panel without a fire button for T and C Series, preconfigured from factory, OK, Fault and Fire LED indication (automatic dimmer function), 9 - 36 V DC, 85 dB buzzer, IP67, -30°C to 70°C, CE, EMC tested, Integrated NO relay output, flush or external mounting, red anodized aluminium body, 55 mm diameter. Includes 1x End-of-line Resistor AER101. Can be used for T Series with a pressure switch Note: Non-programmable
AAP400	Alarm panel with a test button for T and C Series, preconfigured from factory, OK, Fault and Fire LED indication, 10 - 30 V DC, 85 dB buzzer, IP65, -30°C to 70°C, CE, EMC tested, flush or external mounting, powder coated aluminium body, 64x58x30 mm, 0.5 m cable. Includes 2x End-of-line Resistor AER106. Can be used for T Series with a pressure switch Note: Non-programmable
APB210	Panel bracket stainless steel for Alarm Panels AAP210, AAP211 and AAP310
ABP212	Back-up power supply 12 V for Alarm Panels AAP210, AAP211 and AAP310, includes 1 x 7.0 Ah battery. For indoor use only
ABP224	Back-up power supply 24 V for Alarm Panels AAP210, AAP211 and AAP310, includes 2 x 7.0 Ah battery. For indoor use only
ACF001	Case for an external fuse, IP66, -20 up to 70 °C, max 10 A (for AEF001, AEF002, AEF100, AEF200)
ACF002	Case for an external fuse, IP50, max 6.3 A (for AEF001, AEF002, AEF100, AEF200)
AEF002	External fuse 2 A for Alarm Panels AAP210, AAP211 and AAP310
AEF200	External fuse 200 mA for Alarm Panel AAP400



AAP310



AAP400



APB210



ABP212

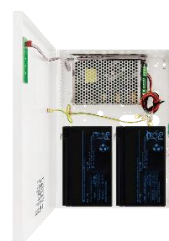

ABP224



ACF001



ACF002



AEF002, AEF200

Table 18: Alarm panel kits

Part No	Content
KAAP310	Alarm Panel AAP310 kit without a fire button for T and C Series, Panel Bracket APB210, 6-pin Deutsch Connector ADC006, Sealing Plugs ADP001, External Fuse AEF002, Fuse Case ACF001, End-of-line Resistor AER101, labels ALA002, ALA004 ALA005
KAAP400	Alarm Panel AAP400 kit with a test button for T and C Series, 6-pin Deutsch Connector ADC006, Sealing Plugs ADP001, External Fuse AEF200, Fuse Case ACF002, End-of-line Resistors AER106, labels ALA004 ALA005



KAAP310



KAAP400

For additional information ask for *CM-AP3 Alarm Panel AAP310 for T Series* or *CM-AP4 Alarm Panel AAP400*.

ANNEX 2: PRESSURE MONITORING AND ELECTRICAL COMPONENTS

A2.1. PRESSURE SWITCH MODELS TXXXFKS

The Pressure Switch models TxxxFKS, is a mechanical switch with one pre-set pressure value (switch point). When the pressure in the system drops below the switch point the pressure switch sends a signal to an Alarm Panel or an external device to perform the designed operation. The pressure switch is supplied with the cable connector and can be monitored by the AAP310 or AAP400 panel for connectivity and faults if required.

The Pressure Switch models TxxxFKS will send a signal when the pressure in the system decreases regardless of the cause, in case of fire or accidental activation or a decrease of pressure in the system which is below the pre-set value. If the cable is disconnected or damaged a fault signal will display on the AAP310 or AAP400 panel if fault monitoring was an installed feature.

The pressure switch can be used as a universal means of sending signal after a T Series system activation. External devices can be informed via the signal (alarm panel, sounder, beacon etc.) or automatic processes can be performed (switching off electrical current, equipment shut-down etc.).

NOTE

In case of malfunction or disconnection of electrical components (Pressure Switch Models TxxxFKS(-E), electrical installations) the T Series system remains fully functional as these components are not used for the systems automatic activation in case of fire. However, functions such as power shut down and fire signalling may be affected.

Table 19: Specifications of Pressure Switch models TxxxFKS

Parameter	Description		
Material of body	nickel plated steel		
Switch point	set to 1 bar (14 psi)		
Switch configuration	open or closed (SPDT)		
Hysteresis	min. 0.3 bar (4 psi) / max. 1 bar (14 psi)		
Switching frequency	max. 100 / min		
Maximum pressure	60 bar		
Power rating	Voltage	Current	
Resistive load AC-12, DC 12	AC 250 V	DC 24 V	4 A
Inductive load AC-14, DC 14	AC 250 V	DC 24 V	2 A
IP rating	IP65 with cable connector and seal		
Electrical outlet	DIN EN 175301-803 A		
Operating temperature	from -20°C up to 100 °C (-4°F to 176°F)		
Tested to:	EN60947 – Low-voltage switchgear and control gear IEC 68-2-78 Permissible air humidity (4K4H per EN 60721-3-4) IEC 60068-2-6 Vibration resistance 10 g (10.....2,000 Hz) IEC 60068-2-27 Shock resistance 30 g		
Advantages	heavy duty, higher power rating, monitoring function, open or closed state		



Pressure Switch models TxxxFKS

TxxxFKS models have a selectable switching function, so it can be set to open or closed state.

1. Connector for closed circuit – for sending signal to an alarm panel, switching on devices (sirens, beacons) or switching off devices using an external relay
2. Connector for open circuit – for switching off connected devices (e.g., ventilation, that is connected in the electric circuit)
3. COM connector
4. ground connector

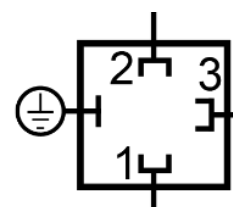

Pressure switch connector

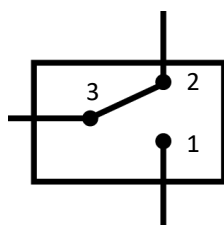

Pressurised

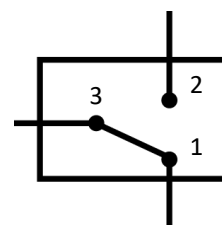

Discharged

IMPORTANT

Diagram on the pressure switch label is at atmospheric pressure (e.g., unpressurised system or discharged system).



1. Fixing screw; use a screwdriver for installation and removal of connector. Tightening torque max. 5 Nm.
2. Electrical connector; use flat head screwdriver to remove from the connector body and connect the electrical cable as per drawing on page 28.
3. Gasket
4. Sealing nut to fix the electrical cable. Below the sealing nut is a grommet. Screw the sealing nut tight in order to seal the electrical cable properly.

A2.2. ECONOMICAL PRESSURE SWITCH MODELS TXXXFKS-E

The Pressure Switch models TxxxFKS-E is a mechanical switch with one pre-set pressure value (switch point). When the pressure in the system drops below the switch point the pressure switch sends a signal to an Alarm Panel or an external device to perform the designed operation.

The Pressure Switch models TxxxFKS-E will send a signal when the pressure in the system decreases regardless of the cause. In case of fire, accidental activation.

The pressure switch can be used as a universal means of sending signal after a T Series system activation. External devices can be informed via the signal (alarm panel, sounder, beacon etc.) or automatic processes can be performed (switching off electrical current, equipment shut-down etc.) using a relay.

Due to physical and chemical properties of the extinguishing agent, at very low ambient temperatures, the vapour pressure of the extinguishing agent could be zero and the pressure switch could send a false alarm signalling zero pressure. Due to this reason when the pressure switch is used on the system it is pressurised with a nitrogen (N₂) so the pressure in the system shall not fall to zero.

Table 20: Specifications of Pressure Switch models TxxxFKS-E

Parameter	Description		
Material of body	brass, nickel plated steel with plastic cover		
Switch point	set to 1 bar (14 psi)		
Switch configuration	open (pressurised) - SPST		
Maximum pressure	30 bar(435 psi)		
Max Power rating DC	50/60 Hz	36 V DC	3 A
Max Power rating AC		240 V AC	
Electrical outlet	2 x wire 0.75 mm ² , 150 mm length		
IP rating	IP54		
Operating temperature	from -20 °C up to 80 °C (-4 °F to 176 °F)		
Tested to:	EN60730 -Automatic electrical controls for household and similar use		
Advantages	light weight, cost-effective		



Pressure Switch models TxxxFKS-E

TxxxFKS-E models have a set switching position:

- pressurised system – contact is open
- no pressure (discharged system) – contacts are closed

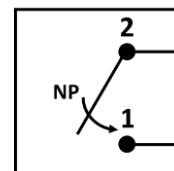

When supplied (pressurised) this is the configuration of the Economical Pressure Switch on models TxxxES-E.

Table 21: Comparison between pressure switch options

	Models "S"	Models "S-E"
Indoor use	✓	✓
Fixed applications	✓	✓
Harsh environments	✓	✓
Outdoor use	✓	✓
Mobile/Vibrating applications	✓	✓
Fault Monitoring	✓	✗



The pressure switch is factory fitted during manufacturing process and must not be tampered with, disassembled or removed. Any user interference will void warranty.



Be aware of the danger posed by the protected equipment. When working in the vicinity of electrical equipment observe corresponding safety rules and instructions. Working on electrical installations may be performed only by qualified persons.



Install the T Series so the pressure switch is not exposed to aggressive chemical substances (caustic, acids, solvents, corrosive substances etc.) and in direct influence of weather conditions.



The pressure switch cannot be in direct contact or be in immediate proximity with parts which heat to temperatures of more than 80 °C (176 °F).

A2.3. CONNECTION TO AN EXTERNAL RELAY

IMPORTANT!

External relay should be sourced by the customer.

An external relay connected to a pressure switch can be an essential safety feature in various systems. When pressure reaches actuation value, the pressure switch sends a signal to the relay. The relay, in turn, activates or deactivates connected devices such as ventilation systems, generators, or other devices. This setup ensures that in the event of agent discharge, the relay can promptly shut down critical equipment to prevent damage or hazardous situations.

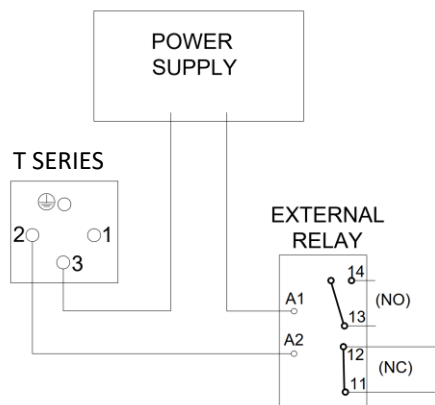

Diagram of TxxxFKS connected to a DPDT relay

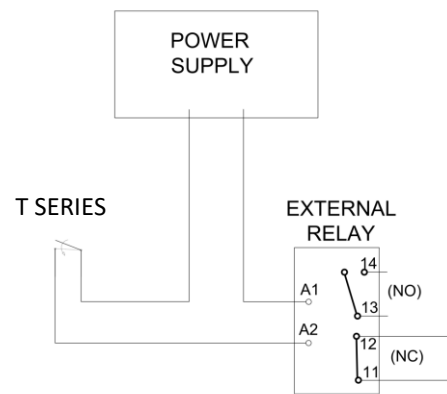

Diagram of TxxxFKS-E connected to a DPDT relay

A2.4. ELECTRICAL CABLES AND CONDUITS

For installation of Pressure Switch models TxxxFKS(-E), the use of a three-core electrical cable for the AAP310 panel is recommended. A two-core electrical cable can be used to connect to other external devices.

Table 22: Specifications of cables

Part №	Description	Comment	Length
ASC002	standard cable, 2x0.75 mm ² , -40°C up to 80 °C, UV stabilized	for standard installations	per metre
ASC004	standard cable 4x0.5 mm ² , -40°C up to 80 °C, UV stabilized	for standard installations	per metre
ASC102	silicone cable 2x0.75 mm ² , -60 °C up to 180 °C, UV stabilized, up to 500 V	for installations with high temperatures	per metre
ASC103	silicone cable 3x0.50 mm ² , -60 °C up to 180 °C, UV stabilized, up to 500 V	for installations with high temperatures	per metre
ASC104	silicone cable 4x0.50 mm ² , -60 °C up to 180 °C, UV stabilized, up to 500 V	for installations with high temperatures	per metre



Standard cable



Silicone cable

Table 23: Silicone cable kits

Part No	Description
KASC102-005	2-core silicone cable kit, 5 metres, 15 cable ties, -60 °C up to 180 °C
KASC102-010	2-core silicone cable kit, 10 metres, 30 cable ties, -60 °C up to 180 °C
KASC102-015	2-core silicone cable kit, 15 metres, 45 cable ties, -60 °C up to 180 °C
KASC102-020	2-core silicone cable kit, 20 metres, 55 cable ties, -60 °C up to 180 °C
KASC103-005	3-core silicone cable kit, 5 metres, 15 cable ties, -60 °C up to 180 °C
KASC103-010	3-core silicone cable kit, 10 metres, 30 cable ties, -60 °C up to 180 °C
KASC103-015	3-core silicone cable kit, 15 metres, 45 cable ties, -60 °C up to 180 °C
KASC103-020	3-core silicone cable kit, 20 metres, 55 cable ties, -60 °C up to 180 °C
KASC104-005	4-core silicone cable kit, 5 metres, 15 cable ties, -60 °C up to 180 °C
KASC104-010	4-core silicone cable kit, 10 metres, 30 cable ties, -60 °C up to 180 °C
KASC104-015	4-core silicone cable kit, 15 metres, 45 cable ties, -60 °C up to 180 °C
KASC104-020	4-core silicone cable kit, 20 metres, 55 cable ties, -60 °C up to 180 °C

In case of installation in spaces with increased risk of damage due to mechanical interference use the cable conduit with conduit connector to protect the electrical cables.

Table 24: Specifications of conduits

Part No	Description	Length
ACC110	Cable conduit, internal \varnothing 10 mm, -40 °C to 120 °C	per metre



Cable conduit ACC110

